



SMART DIAMOND  
— TOOLS PTY LTD —

redback



**REDBACK H15V**

**H Class  
Dust Extractor**

**\$2045 + GST**

- 2 Stage HEPA filtration
- 1x 1700W Motor
- 1700W 10A
- Airflow 300m<sup>3</sup>/h 176cfm
- Continuous bagging system
- 5m x 38mm Hose with fittings, 38mm wand, crevice tool and floor head
- 110cm (H) x 40cm (W) x 66cm (D)
- 40kg



SMART DIAMOND  
— TOOLS PTY LTD —

redback



**REDBACK H22**

**H Class  
Dust Extractor**

**\$3499 + GST**

- 2 Stage HEPA filtration
- 2x 1200W Independently switched motors
- 2400W 10A
- Airflow 400m<sup>3</sup>/h 236cfm
- Continuous bagging system
- 7.5m x 50mm Hose with fittings, 50mm wand, crevice tool and floor head
- 129cm (H) x 57cm (W) x 63cm (D)
- 50.5 kg



SMART DIAMOND  
— TOOLS PTY LTD —



redback

## REDBACK H32

H Class  
Dust Extractor  
\$5270 + GST

- 2 Stage HEPA filtration
- 3x 1200W Independently switched motors
- 3600W 15A
- Airflow 600m<sup>3</sup>/h 354cfm
- Continuous bagging system
- 7.5m x 50mm Hose with fittings, 50mm wand, crevice tool and floor head
- 150cm (H) x 57cm (W) x 76cm (D)
- 61.5 kg

# TIV-1000 - \$2,190

## Single phase 1 motor HEPA dust extractor

TIV-1000 is equipped with a conical pre filter and one H13 HEPA filter. The main filter with 1.7 m<sup>2</sup> filter surface, each of the HEPA filter is independently tested and certified. TIV-1000 can separate the fine dust with efficiency > 99.99% @ 0.3 μm, ensuring your work space is a clean and safe environment. TIV-1000 is recommended for small grinders and hand held power tools.



### Main features:

1. OSHA compliant H13 HEPA filter
2. "No marking type" rear wheels and lockable front caster.
3. Efficient jet pulse filter cleaning.
4. Continuous bagging system ensures quick and dust-free bag changes
5. Smart and portable design, transporting is like a breeze.

Model	TIV-1000
Power (kw)	1.2kw
Voltage	240V 50/60Hz
Amps	4
Airflow (m <sup>3</sup> /h)	200
Vacuum (mBar)	220
Pre-filter	1.7m <sup>2</sup> >99.5% @ 1.0um
Hepa filter(H13)	1.2m <sup>2</sup> >99.99% @ 0.3um
Filter cleaning	Jet pulse filter cleaning
Dimension (mm)	420X680X1100
Weight (kg)	30
Collection	Continuous drop-down bag

Standard accessory	
	
D38 brush	D38 S wand 2-pc
	
D38 solid hose cuff	
	
D38 soft hose cuff	D38 EVA hose, 5.0m



Jet pulse filter cleaning



Pre-filter (F8)



Hepa filter(H13)

# TIV-2000 - \$3,400

## Single phase 2 motors HEPA dust extractor

TIV-2000 is a two engine HEPA dust extractor. It is equipped with a main filter as the first and two H13 filter as the final. Each HEPA filter is individually tested and certified to have a minimum efficiency of 99.99% at 0.3 microns, which meets the new silica requirements. This professional dust extractor is excellent for building, grinding, plaster and concrete dust.

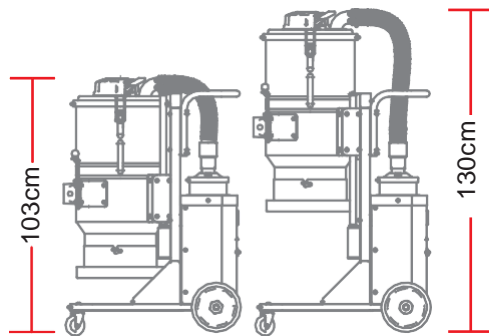

### Main features:

1. OSHA compliant H13 HEPA filter
2. Unique jet pulse filter cleaning system, efficiently purges the pre-filter without opening the vacuum to maintain a smooth airflow, and to avoid creating a second dust hazard
3. The height of the vacuum can be lowered to 103cm, use little space as possible when transporting.
4. An hour counter and vacuum meter for filter control are standard

Model	TIV-2000
Power (kw)	2.4kw
Voltage	240V 50/60Hz
Amps	8
Airflow (m <sup>3</sup> /h)	400
Vacuum (mBar)	220
Pre-filter	3.0m <sup>2</sup> >99.5%@1.0um
Hepa filter(H13)	2.4m <sup>2</sup> >99.99%@0.3um
Filter cleaning	Jet pulse filter cleaning
Dimension (mm)	570 * 710 * 1030/1300
Weight (kg)	55
Collection	Continuous drop-down bag

Standard accessory	
	
D50 floor brush	D50S wand, aluminum
	
D70/50 reducer	D50 EVA hose, 7.5m
	
D50 hose cuff, 2-pc	



Jet pulse filter cleaning



Pre-filter (F8)



Hepa filter(H13)

# TIV-3000 - \$5,200

## Single phase 3 motors HEPA dust extractor

TIV-3000 is a HEPA concrete dust extractor. With 3 large Ametek motors, TS3000 has plenty power to be connected to any mid or larger size grinders, scarifiers, shot blasters to extract freshly cut, friable concrete dust. Certified HEPA filtration to 99.99% @ 0.3 microns to guarantee that the vacuum exhaust is absolutely dust-free. TIV-3000 is supplied with a complete tool kit, including hose, wand and floor tools.

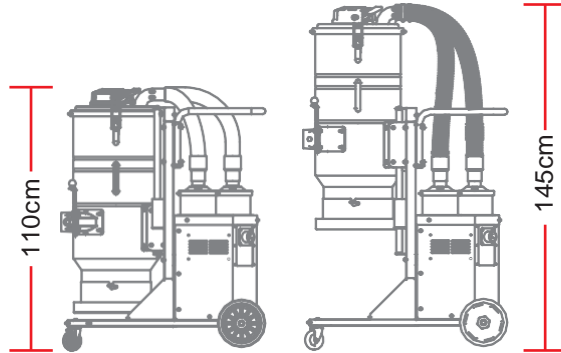

### Main features:

1. OSHA compliant H13 HEPA filter
2. Unique jet pulse filter cleaning technology ensures efficient and clean filtration.
3. Welded frame/platform provide sturdy support in tough jobsite.
4. The 22 meters long plastic bag can be separated to approximately 40 individually sealed bags for fast, safe handling and disposal of dust.
5. The height of the vacuum can be lower to 110cm, use little space as possible when transporting.

Model	TIV-3000
Power (kw)	3.6kw
Voltage	240V 50/60Hz
Amps	12
Airflow (m <sup>3</sup> /h)	600
Vacuum (mBar)	220
Pre-filter	4.5m <sup>2</sup> >99.5%@1.0um
Hepa filter(H13)	3.6m <sup>2</sup> >99.99%@0.3um
Filter cleaning	Jet pulse filter cleaning
Dimension (mm)	630 * 840 * 1100/1450
Weight (kg)	70
Collection	Continuous drop-down bag



Jet pulse filter cleaning



Pre-filter (F8)



Hepa filter(H13)

### Standard accessory



D50 floor brush



D50S wand, aluminum



D70/50 reducer



D50 EVA hose, 7.5m



D50 hose cuff, 2-pc



D63 PU hose, 10m



D70/63 reducer

# TIS40 - \$2,350

## TIS40 Pre separator

When large amount of dust produced during the grinding, it is advisable to use a pre separator. The special cyclone system captures **95%** of the material before vacuuming, greatly improve the filter efficiency and protect your dust extractor from clogging easily. TIS40 can be used in conjunction with all common industrial vacuums and dust extractors .

Model	TIS40
Collection	Continuous drop-down bag
Dimension (mm)	600 X 710 X 1250/1520
Weight (kg)	40



### Main features:

1. More efficient work performance without interrupted often to clean the filter.
2. Continuous bagging system to collect the dust easily.
3. Very low cost maintenance